

**CNI & LINDE STYLE**

# INDEX

	PAGE		PAGE
Accessory Kits	20	Handles	19
Back Caps	19	Hook Up Kits	20
Cable Covers	14	Hoses	18
Collets	12	Nozzles	See CUPS 14-17
Collet Bodies	12,13	*O* Rings	13
Cups		Power Cable Adapters	20
Alumina	16,17	Power Cables	18
Lava	14,15	Torches & Packages	2-11,21
Cup Gaskets	13	Torch Parts - Replacement	19
Dinse	20		

**AIRCO STYLE**

	PAGE		PAGE
Accessory Kits	28	Handles	28
Back Caps	27	Nose Blocks	27
Collets	28	Nozzles	See CUPS 26,27
Cups		*O* Rings	27
Alumina	27	Power Cable Adapters	28
Lava	26	Torches & Packages	22-25

# TIG TORCH HOOK-UP DIAGRAMS

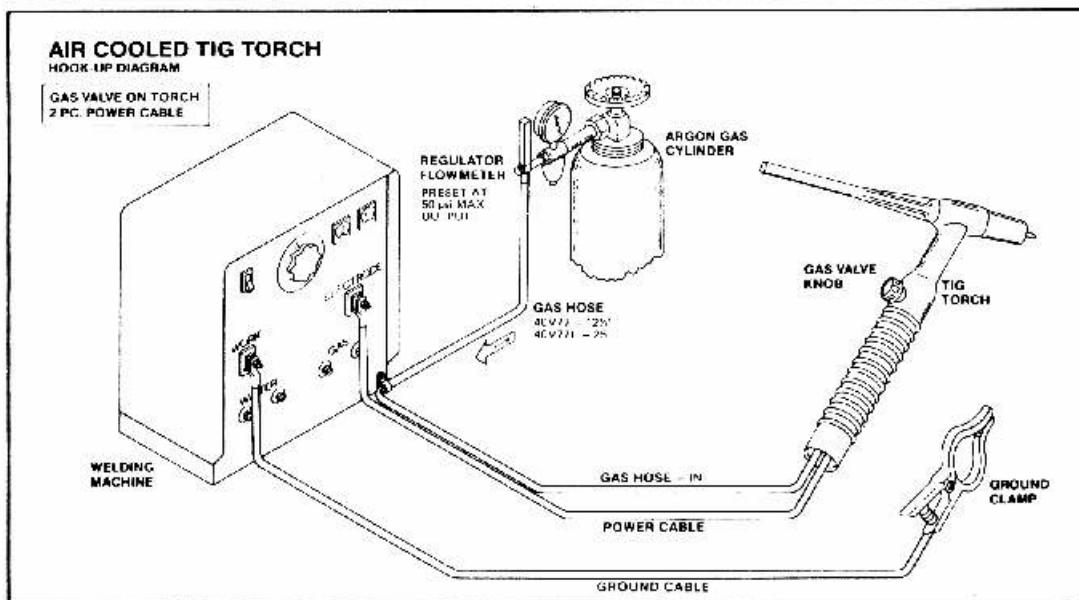
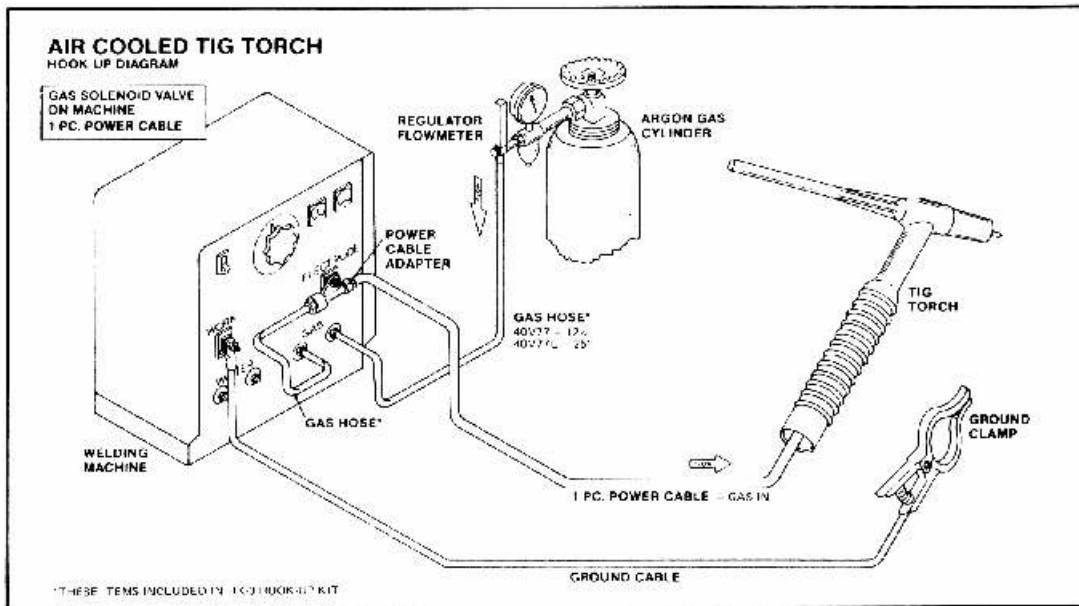
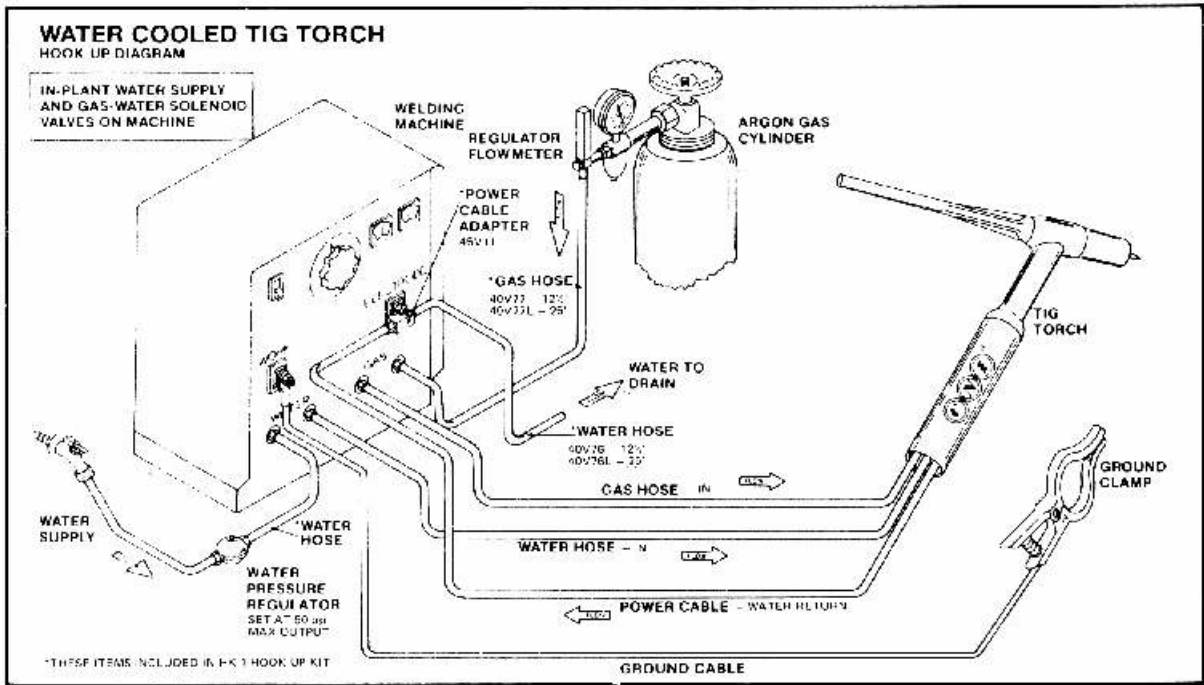

**CNI-9**

**CNI-9VH**

**CNI-9S**

**AIR COOLED TIG TORCH**  
 Available With Heavy Duty Rubber Power Cable  
 or 2 Piece Power Cable

- Capacity . . . . . 125 amps
- Weight, less cable . . . . . 3 oz.
- Electrode Capacity . . . . . .020 - 3/32"

- SILICONE RUBBER INSULATION
- INTERCHANGEABLE PARTS
- QUALITY CONSTRUCTION
- COMPACT & LIGHTWEIGHT



DESCRIPTION	PART NO.	DESCRIPTION	PART NO.
TORCH BODY	CNI-9	** TORCH PACKAGE	CNI-9-25
TORCH BODY with Valve	CNI-9VH	INCLUDES: CNI-9 Torch Body, Handle	
STRAIGHT TORCH BODY	CNI-9S	Medium Back Cap, 25' Power Cable	
**TORCH PACKAGE	CNI-9-12	** Power Cable Adaptor - Optional	105Z57
INCLUDES: CNI-9 Torch Body, Handle, Medium Back Cap, 12½' Power Cable			

## ACCESSORIES - REPLACEMENT PARTS

DESCRIPTION	PART NO.	DESCRIPTION	PART NO.
Back Cap Insulator	CNI-9-4	Rubber Power Cable 12½ Ft.	57Y01R
Cup Gasket	598882	Rubber Power Cable 25 Ft.	57Y03R
Short Back Cap	41V33	2 pc. Power Cable 12½ Ft.	57Y01-2
Medium Back Cap	41V35	2 pc. Power Cable 25 Ft.	57Y03-2
Long Back Cap	41V24	Gas Extension Hose 12½ Ft.	40V77
Handle (for CNI-9 & 9S)	53N06	Hook Up Kit (for torches with built-in gas valve)	HK-2
Handle (for CNI-9VH)	105Z55	Hook Up Kit (for torches using gas solenoid valve on machine)	HK-3
Argon Valve Assembly for CNI-9	V-2	Parts Kit	AK-20
Power Cable Adaptor	105Z57	Cable Covers 10 Ft. & 20 Ft.	CC-10,CC-20
Valve Stem	VS-2		
Valve Stem "O" Ring	17VS0		
Accessory Kit	AK-1		

## COLLET BODIES & COLLETS

Electrode Diam. (in.)	.020	.040	1/16	3/32
Collet	13N20	13N21	13N22	13N23
Collet Body	13N25	13N26	13N27	13N28
Collet Body Gas Lens	45V41	45V42	45V43	45V44

## GAS CUPS

Cup No.	3	4	5	6	7	8	10
Ceramic		13N14	13N15	13N16	13N17	13N18	13N19
Ceramic 1 7/8" Long	796F70	796F71	796F72	796F73	—	—	—
Ceramic 2 1/2" Long	796F74	796F75	796F76	796F77	—	—	—
Alumina	—	13N08	13N09	13N10	13N11	13N12	13N13
Alumina Gas Lens	—	53N58	53N59	53N60	53N61	—	—

**Interchangeable Parts** — The CNI-9 uses the same gas cups, collets, collet bodies, back caps as the CNI-9S, 9VH, CNI-20, CNI-20S, and "Linde" HW-20 and HW-25 Torches.

CNI-9 torches use the same power cables as "Linde" HW-17 torches.

# CNI-90PH TORCH



## AIR COOLED TIG TORCH

- Capacity ..... 125 amps continuous duty.
- Weight, less power cable ..... 2 oz.
- Electrode capacity ..... 020 - 1/16 in.
- MOLDED PHENOLIC BODY
- INTERCHANGEABLE PARTS
- QUALITY CONSTRUCTION
- COMPACT & LIGHTWEIGHT



PHENOLIC

DESCRIPTION	PART NO.	DESCRIPTION	PART NO.
TORCH BODY	CNI-90PH	**TORCH PACKAGE WITH VALVE	CNI-90PH-V-12
**TORCH PACKAGE	CNI-90PH-12	Includes: CNI-90PH Torch Body	
Includes: CNI-90PH Torch Body		Valve – V-2	
Handle		Short Torch Cap	
Short Torch Cap		12 1/2' Power Cable	
12 1/2' Power Cable		**TORCH PACKAGE WITH VALVE	CNI-90PH-V-25
**TORCH PACKAGE	CNI-90PH-25	Includes: CNI-90PH Torch Body	
Includes: CNI-90PH Torch Body		Valve – V-2	
Handle		Short Torch Cap	
Short Torch Cap		25' Power Cable	
25' Power Cable			

\*\*Power Cable Adaptor – Optional

### ACCESSORIES – REPLACEMENT PARTS

DESCRIPTION	PART NO.	DESCRIPTION	PART NO.
Short Torch Cap	84Z31	Power Cable (12 1/2')	56Y38
Long Torch Cap	56Y40	Power Cable (25')	56Y97
Handle	84Z28	O Ring	85W49
Argon Valve Assembly "40V92"	V-2 Valve	Sleeve	105Z26
Power Cable Adaptor	53N43	Adaptor	45V52
		Insulator	53N85

### COLLET BODIES & COLLETS

Electrode Diam. (in.)	.020	.040	1/16
Collet	84Z34	84Z35	84Z33
Collet Body	105Z27	105Z27	105Z27
Collet Body Gas Lens*	45V41	45V42	45V43

\*An adaptor (45V52) and insulator (53N85) are also required when using a gas lens.

### GAS CUPS

Cup No.	3	4	5	6
Ceramic	10005	84Z36	84Z37	84Z38
Ceramic 1 7/8" Long	10045	10046	10047	10048
Alumina		14N65	14N66	14N67
Alumina Gas Lens		53N58	53N59	53N60
Alumina 1 7/8" Long		14N73	14N74	14N75



## AIR COOLED TIG TORCH

Available With Heavy Duty Rubber Power Cable  
 or 2 Piece Power Cable

- Capacity ..... 130 amps  
continuous duty.
- Weight, less power cable ..... 5 oz.
- Electrode capacity ..... .020 - 3/32"
- SILICON RUBBER INSULATION
- INTERCHANGEABLE PARTS
- QUALITY CONSTRUCTION



NOTE: for PHENOLIC Torches add "PH"  
 to Part No.

DESCRIPTION	PART NO.	DESCRIPTION	PART NO.
TORCH BODY Includes: Cup Gasket	CNI-17	**TORCH PACKAGE WITH VALVE Includes: CNI-17 Torch Body, Long Torch Cap, 12 1/2' Power Cable, Valve Same with 2 Piece Power Cable	CNI-17V-12
**TORCH PACKAGE Includes: CNI-17 Torch Body, Long Torch Cap, Handle, 12 1/2' Power Cable Same with 2 Piece Power Cable	CNI-17-12	**TORCH PACKAGE WITH VALVE Includes: CNI-17 Torch Body, Long Torch Cap, 25' Power Cable, Valve Same with 2 Piece Power Cable	CNI-17V-12-2PC CNI-17V-25
**TORCH PACKAGE Includes: CNI-17 Torch Body, Long Torch Cap, Handle, 25' Power Cable Same with 2 Piece Power Cable	CNI-17-12-2PC CNI-17-25		CNI-17V-25-2PC
	CNI-17-25-2PC	**Power Cable Adaptor — Optional	

## ACCESSORIES – REPLACEMENT PARTS

DESCRIPTION	PART NO.	DESCRIPTION	PART NO.
Back Cap Insulator	CNI-18-7	Power Cable Adaptor	105Z57
Collet Body Insulator	54N01	Torch Body O Ring	2-110
Cup Gasket	CNI-18CG	Argon Valve Assembly (40V92)	Valve V-2
Short Torch Cap	57Y04	Accessory Kit	AK-2
Long Torch Cap	57Y02	Hook Up Kit (for torches with slide valve)	HK-2
Handle	105Z55	Hook Up Kit (for torches using gas solenoid valve on machine)	HK-3
Power Cable (12 1/2')	57Y01	Two Piece Connector & Nipple	CNI-17-2
Power Cable (25')	57Y03	Valve O Ring	V-2-6
Two Piece Power Cable (12 1/2')	57Y01-2	Lug	LUG-62
Two Piece Power Cable (25')	57Y03-2	Two Piece Argon Hose-12-1/2 Ft.	45V09-2
Gas Extension Hose (12 1/2')	40V77	Two Piece Argon Hose-25 Ft.	45V10-2
Parts Kit	AK-18		

## COLLET BODIES & COLLETS

Electrode Diam. (in.)	.020	.040	1/16	3/32
Collet	10N21	10N22	10N23	10N24
Collet Body	10N29	10N30	10N31	10N32
*Collet Body Gas Lens	45V29	45V24	45V25	45V26

\*Collet Body Insulator #54N01 Required When Using Gas Lens Collet Body

## GAS CUPS

Cup No.	4	5	6	7	8	10	12
Ceramic	105Z43	105Z42	105Z44	105Z45	08N78	08N79	08N80
Ceramic Gas Lens	54N35	54N34	54N33	54N32	54N31	—	—
Ceramic Long 3-7/32"	12N03	105Z60	12N02	105Z61	10065	—	—
Alumina	10N50	10N49	10N48	10N47	10N46	10N45	10N44
Alumina Gas Lens	54N18	54N17	54N16	54N15	54N14	—	—
Alumina Long 3'	—	10N49L	10N48L	10N47L	—	—	—
Alumina Gas Lens Long 3'	—	54N17L	54N16L	54N15L	—	—	—

Interchangeable Parts — The CNI-17 uses the same gas cups, collets, collet bodies, and torch caps as the CNI-18, CNI-26 and "Linde" HW-17, HW-18, and HW-26 torches.

# CNI-17VH TORCH

## AIR COOLED TIG TORCH

Available With Heavy Duty Rubber Power Cable  
or 2 Piece Power Cable

- Capacity ..... 130 amps continuous duty.
- Weight, less power cable ..... 5 oz.
- Electrode capacity ..... 020 - 3/32"

- SILICON RUBBER INSULATION
- INTERCHANGEABLE PARTS
- QUALITY CONSTRUCTION



DESCRIPTION	PART NO.	DESCRIPTION	PART NO.
TORCH BODY Includes: Cup Gasket	CNI-17VH	**TORCH PACKAGE WITH VALVE IN HEAD	CNI-17VH-25
**TORCH PACKAGE WITH VALVE IN HEAD	CNI-17-VH-12	Includes: CNI-17VH Torch Body, Long Torch Cap, 25' Power Cable,	
Includes: CNI-17VH Torch Body, Long Torch Cap, 12 1/2" Power Cable		Same with 2 Piece Power Cable	CNI-17VH-25-2PC
Same with 2 Piece Power Cable	CNI-17VH-12-2PC	**Power Cable Adaptor – Optional	105Z57

## ACCESSORIES – REPLACEMENT PARTS

DESCRIPTION	PART NO.	DESCRIPTION	PART NO.
Back Cap Insulator	CNI-18-7	Power Cable Adaptor	105Z57
Collet Body Insulator	54N01	Accessory Kit	AK-2
Cup Gasket	CNI-18CG	Hook Up Kit (for torches with built in gas valve)	HK-2
Short Torch Cap	57Y04	Hook Up Kit (for torches using gas solenoid valve on machine)	HK-3
Long Torch Cap	57Y02	Two Piece Connector & Nipple	CNI-17-2
Handle	105Z55	Valve Stem O Ring	CNI-17VSO
Rubber Power Cable (12 1/2')	57Y01-R	Valve Stem Assembly	VS-2
Rubber Power Cable (25')	57Y03-R	Replacement Argon Hose 12 1/2' - 2 Pc	45V09-2
Two Piece Power Cable (12 1/2')	57Y01-2	Replacement Argon Hose 25' - 2 Pc	45V10-2
Two Piece Power Cable (25')	57Y03-2	Parts Kit	AK-18
Gas Extension Hose (12 1/2')	40V77		

## COLLET BODIES & COLLETS

Electrode Diam. (in.)	.020	.040	1/16	3/32
Collet	10N21	10N22	10N23	10N24
Collet Body	10N29	10N30	10N31	10N32
*Collet Body Gas Lens	45V29	45V24	45V25	45V26

\*Collet Body Insulator #54N01 Required When Using Gas Lens Collet Body

## GAS CUPS

Cup No.	4	5	6	7	8	10	12
Ceramic	105Z43	105Z42	105Z44	105Z45	08N78	08N79	08N80
Ceramic Long 3-7/32"	54N35	54N34	54N33	54N32	10065	—	—
Ceramic Long 3-7/32"	12N03	105Z60	12N02	105Z61	10065	—	—
Alumina	10N50	10N49	10N48	10N47	10N46	10N45	10N44
Alumina Gas Lens	54N18	54N17	54N16	54N15	54N14	—	—
Alumina Long 3"	—	10N49L	10N48L	10N47L	—	—	—
Alumina Gas Lens Long 3"	—	54N17L	54N16L	54N15L	—	—	—

**Interchangeable Parts** — The CNI-17VH uses the same gas cups, collets, collet bodies, and torch caps as the CNI-17, CNI-18 CNI-26 and "Linde" HW-17, HW-18, and HW-26 torches.

### WATER COOLED TIG TORCH

- Capacity ..... 350 amps  
continuous duty.
- Weight, less cable and hoses .... 7 oz.
- Cooling requirements ..... 1 qt. per min.
- Electrode capacity ..... 020 - 5/32 in.



- SILICON RUBBER INSULATION - CNI-18
- PHENOLIC - CNI-18PH
- SUPERIOR WATER COOLING
- INTERCHANGEABLE PARTS
- QUALITY CONSTRUCTION

DESCRIPTION	PART NO.	DESCRIPTION	PART NO.
TORCH BODY Includes: Cup Gasket	CNI-18	*TORCH PACKAGE Includes: CNI-18 Torch Body Long Torch Cap Handle 25' Power Cable & Hoses	CNI-18-25
*TORCH PACKAGE Includes: CNI-18 Torch Body Long Torch Cap Handle 12 1/2' Power Cable & Hoses	CNI-18-12	*Power Cable Adaptor - Optional	45V11

### ACCESSORIES - REPLACEMENT PARTS

DESCRIPTION	PART NO.	DESCRIPTION	PART NO.
Gas Valve (Mounts in Gas Hose)	V-1	Gas Hose (12 1/2')	40V75
Collet Body Insulator	54N01	Gas Hose (25')	41V30
Cup Gasket	CNI-18CG	Water Extension Hose (12 1/2')	40V76
Back Cap Insulator	CNI-18-7	Gas Extension Hose (12 1/2')	40V77
Short Torch Cap	57Y04	Power Cable Adaptor	45V11
Long Torch Cap	57Y02	Torch Body O Ring	18026
Handle	10N15	Hook Up Kit	HK-1
Rubber Power Cable (12 1/2')	40V64R	Accessory Kit	AK-3
Rubber Power Cable (25')	41V29R	Wire Hose Clamp	98W43
Water Hose (12 1/2')	40V74	Parts Kit	AK-18
Water Hose (25')	41V32	Power Cable-25 ft. mach. ftg. both ends Adaptor - Machine Fittings	41V29-M 11N19

### COLLET BODIES & COLLETS

Electrode Diam. (in.)	.020	.040	1/16	3/32	1/8	5/32
Collet	10N21	10N22	10N23	10N24	10N25	54N20
Collet Body	10N29	10N30	10N31	10N32	10N28	406488
Gas Lens Collet Body*	45V29	45V24	45V25	45V26	45V27	45V28

\*Collet Body Insulator #54N01 Required When Using Gas Lens Collet Body

### GAS CUPS

Cup No.	4	5	6	7	8	10	12
Ceramic	105Z43	105Z42	105Z44	105Z45	08N78	08N79	08N80
Ceramic Gas Lens	54N35	54N34	54N33	54N32	54N31	--	--
Ceramic Long 3 7/32"	12N03	105Z60	12N02	105Z61	10065	--	--
Alumina	10N50	10N49	10N48	10N47	10N46	10N45	10N44
Alumina Long 3"	--	10N49L	10N48L	10N47L	--	--	--
Alumina Gas Lens	54N18	54N17	54N16	54N15	54N14	--	54N19 Short
Alumina Long Gas Lens 3"	--	54N17L	54N16L	54N15L	--	--	--

**Interchangeable Parts** - The CNI-18 uses the same gas cups, collets, collet bodies, and torch caps as the CNI-17 and CNI-26 and "Linde" HW-17, HW-18, and HW-26 Torches.



# CNI-18S TORCH



## WATER COOLED MACHINE TIG TORCH

- Capacity ..... 500 amps continuous duty.
- Cooling requirements ..... 1.5 qt/min @ 45 p.s.i.
- Electrode capacity ..... 020 - 3/16 in.
- \*● Barrel ..... 10" long x 1 3/8" Dia.
- \*\*● Rack ..... 24 or 32 Pitch  
24 Pitch – 1/4 x 8"  
32 Pitch – 3/16 x 8"

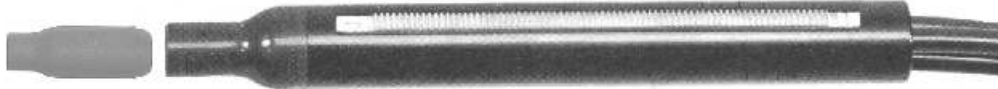

DESCRIPTION	PART NO.	DESCRIPTION	PART NO.
TORCH BODY Includes: Cup Gasket	CNI-18-S	***TORCH PACKAGE Includes: CNI-18S Torch Body Barrel and Rack 25' Power Cable & Hoses	CNI-18S-25
***TORCH PACKAGE Includes: CNI-18S Torch Body Barrel and Rack 12 1/2' Power Cable & Hoses	CNI-18S-12		

\*Barrel Length – 10" standard, up to 24" long on special order.

\*\*Rack Pitch – 24 Pitch Standard, 32 Pitch Optional.

\*\*\*Power Cable Adaptor – Optional.

### ACCESSORIES – REPLACEMENT PARTS

DESCRIPTION	PART NO.	DESCRIPTION	PART NO.
Cup Gasket	CNI-18CG	Gas Hose (12 1/2')	40V75
Barrel (10" x 1 3/8" Diameter)	18S-B	Gas Hose (25')	41V30
Rack – 24 Pitch	18R24	Water Extension Hose (12 1/2')	40V76
Rack – 32 Pitch	18R32	Gas Extension Hose (12 1/2')	40V77
Power Cable (12 1/2')	40V64P	Power Cable Adaptor	45V11
Power Cable (25')	41V29P	Torch Body O Ring	116
Water Hose (12 1/2')	40V74P	Gas Lens Insulator	54N01
Water Hose (25')	41V32P	Wire Hose Clamp	98W43

### COLLET BODIES & COLLETS

Electrode Diam. (in.)	.020	.040	1/16	3/32	1/8	5/32	3/16
Collet	10N21	10N22	10N23	10N24	10N25	54N20	30028
Collet Body	10N29	10N30	10N31	10N32	10N28	406488	30126
*Gas Lens Collet Body	45V29	45V24	45V25	45V26	45V27	45V28	—

\*Collet Body Insulator #54N01 Required When Using Gas Lens Collet Body

### GAS CUPS

Cup No.	4	5	6	7	8	10	12
Ceramic	105Z43	105Z42	105Z44	105Z45	08N78	08N79	08N80
Ceramic Gas Lens	54N35	54N34	54N33	54N32	54N31	—	—
Ceramic Long 3" 7/32"	12N03	105Z60	12N02	105Z61	10065	—	—
Alumina	10N50	10N49	10N48	10N47	10N46	10N45	10N44
Alumina Long 3"	—	10N49L	10N48L	10N47L	—	—	—
Alumina Gas Lens	54N18	54N17	54N16	54N15	54N14	—	54N19 Short
Alumina Long Gas Lens 3"	—	54N17L	54N16L	54N15L	—	—	—

**Interchangeable Parts** – The CNI-18S uses the same gas cups, collets, collet bodies, and torch caps as the CNI-17 and CNI-26 and "Linde" HW-17, HW-18, and HW-26 Torches.



### WATER COOLED TIG TORCH

- Capacity ..... 250 amps continuous duty (12 1/2' lines).
- Weight, less cable and hoses ... 3.5 oz.
- Cooling requirements ..... 1 qt. per min.
- Electrode capacity ..... .020 - 1/8 in.



- SILICONE RUBBER INSULATION
- SUPERIOR WATER COOLING
- INTERCHANGEABLE PARTS
- QUALITY CONSTRUCTION

DESCRIPTION	PART NO.	DESCRIPTION	PART NO.
TORCH BODY Includes: Cup Gasket	CNI-20	*TORCH PACKAGE Includes: CNI-20 Torch Body Medium Torch Cap Handle 25' Power Cable & Hoses	CNI-20-25
*TORCH PACKAGE Includes: CNI-20 Torch Body Medium Torch Cap Handle 12 1/2' Power Cable & Hoses	CNI-20-12	*Power Cable Adaptor – Optional	45V11

### ACCESSORIES – REPLACEMENT PARTS

DESCRIPTION	PART NO.	DESCRIPTION	PART NO.
Gas Valve (Mounts in Gas Hose)	V-1	Handle for Heavy Duty Rubber Cable	53N06HD
Cup Gasket	598882	Handle Adaptor for 53N06HD	HA-20
Back Cap Insulator	CNI-9-4	Water Hose (12 1/2')	45V07
Short Torch Cap	41V33	Water Hose (25')	45V08
Medium Torch Cap	41V35	Gas Hose (12 1/2')	45V09
Long Torch Cap	41V24	Gas Hose (25')	45V10
Wire Hose Clamp	53N04	Power Cable Adaptor	45V11
Handle	53N06	Accessory Kit	AK-4
Rubber Power Cable (12 1/2')	45V03R	Hook Up Kit	HK-1
Rubber Power Cable (25')	45V04R	Parts Kit	AK-20

### COLLET BODIES & COLLETS

Electrode Diam. (in.)	.020	.040	1/16	3/32	1/8
Collet	13N20	13N21	13N22	13N23	13N24
Collet Body	13N25	13N26	13N27	13N28	13N29
Gas Lens Collet Body	45V41	45V42	45V43	45V44	45V45

### GAS CUPS

Cup No.	3	4	5	6	7	8	10
Ceramic	—	13N14	13N15	13N16	13N17	13N18	13N19
Ceramic Long 1 7/8"	796F70	796F71	796F72	796F73	—	—	—
Ceramic Long 2 1/2"	796F74	796F75	796F76	796F77	—	—	—
Alumina	—	13N08	13N09	13N10	13N11	13N12	13N13
Alumina Gas Lens	—	53N58	53N59	53N60	53N61	—	—

**Interchangeable Parts** – The CNI-20 uses the same gas cups, collets, collet bodies, and torch caps as the CNI-9, CNI-9S, CNI-20S and "Linde" HW-20 and HW-25 torches.

# CNI-24 AND 24W TORCH

## CNI-24 AIR COOLED TIG TORCH



CNI-24-60°\*\*  
Silicone Rubber Torch Body

- 80 amps continuous duty
- Weight, less power cable - 1 oz.
- Electrode Capacity - .020 - 1/16"
- Interchangeable Parts



CNI-24VH-60°  
Silicone Rubber Torch Body  
with Built-in Valve



## CNI-24W WATER COOLED TIG TORCH



CNI-24W-60°  
Silicone Rubber Torch Body

- 180 amps continuous duty
- Weight less cable & hoses - 1.5 oz.
- Electrode Capacity - .020 - 1/16"
- Compact & Lightweight

### AIR COOLED TORCHES

DESCRIPTION	PART NO.
TORCH BODY - includes gasket	CNI-24-60°
TORCH BODY - with valve	CNI-24VH-60°
*TORCH PACKAGE Includes: CNI-24 Torch Body, Handle, 12½' Power Cable	CNI-24-12-60°
*TORCH PACKAGE Includes: CNI-24 Torch Body, Handle, 25' Power Cable	CNI-24-25-60°
*TORCH PACKAGE WITH VALVE add VH to Part Number	CNI-24VH-12-60° CNI-24VH-25-60°

### WATER COOLED TORCHES

DESCRIPTION	PART NO.
TORCH BODY - WATER COOLED	CNI-24W-60°
TORCH PACKAGE Includes: CNI-24W Torch Body, Handle, 12½' Power Cable & Hoses	CNI-24W-12-60°
TORCH PACKAGE Includes: CNI-24W Torch Body, Handle, 25' Power Cable & Hoses	CNI-24W-25-60°
Power Cable Adaptor - Optional	45V11

\*Power Cable Adapter 53N43 – Optional

Available in Phenolic

### ACCESSORIES – REPLACEMENT PARTS

DESCRIPTION	PART NO.	DESCRIPTION	PART NO.
Insulating Gasket	53N22	Collet Body Insulator (Gas Lens)	53N66
Power Cable Adaptor (Air Cooled)	53N43	Collet Body Wrench	53N20
Power Cable Adaptor (Water Cooled)	45V11	Hook-up Kit (torches with valve)	HK-2
Handle	53N21	Hook-up Kit (gas solenoid valve on machine)	HK-3
Gas Extension Hose (12½')	40V77	Wire Hose Clamp (water cooled torch)	53N04
Gas Control Valve (Air Cooled)	V-2		
Adaptors for V-2 Valve	9A-M,9A-F		

### COLLET BODIES & COLLETS

Electrode Diam. (in.)	.020	.040	1/16
Collet	53N15	53N16	53N14
Collets For Gas Lens Collet Bodies	53N62	53N63	53N64
Collet Body	53N17	53N18	53N19
*Gas Lens Collet Body	45V41	45V42	45V43

\*Collet Body Insulator 53N66 Required.



### GAS CUPS

Cup No.	.165	4	5	6	7
Ceramic 5/8"	53N23	53N24	53N25	53N27	—
Ceramic 1 1/8"	—	53N28	—	53N26	—
Alumina Gas Lens	—	53N58	53N59	53N60	53N61

Interchangeable Parts — CNI-24 uses the same gas cups, collets, collet bodies as "Linde" HW-24 Torches.

## AIR COOLED TIG TORCH

Available With Heavy Duty Rubber Power Cable  
or 2 Piece Power Cable

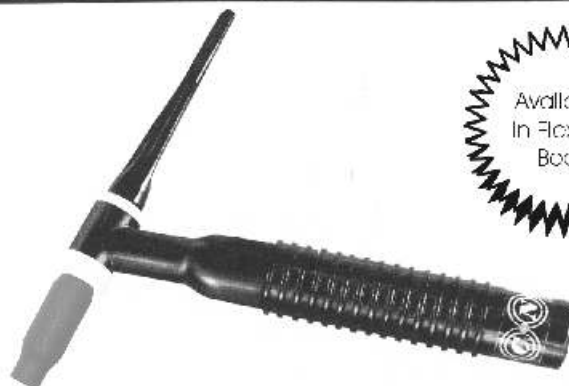

- Capacity ..... 200 amps  
continuous duty
- Weight, less cable and hoses .... 10 oz.
- Electrode capacity ..... 020 - 5/32 in.
  - SILICONE RUBBER INSULATION
  - INTERCHANGEABLE PARTS
  - QUALITY CONSTRUCTION

NOTE: for PHENOLIC Torches add "PH"  
to Part No.

DESCRIPTION	PART NO.	DESCRIPTION	PART NO.
TORCH BODY Includes: Cup Gaskets	CNI-26	**TORCH PACKAGE Includes: CNI-26 Torch Body Long Back Cap, Handle 25' Power Cable	CNI-26-25
**TORCH PACKAGE Includes: CNI-26 Torch Body Long Back Cap, Handle 12½ Power Cable	CNI-26-12	TORCH PACKAGE Same as above but with two piece power cable	CNI-26-25-2PC
TORCH PACKAGE Same as above but with two piece power cable.	CNI-26-12-2PC	Power cable adaptor not necessary with 2-PC power cable	
		**Power Cable Adaptor — Optional	45V62

## ACCESSORIES - REPLACEMENT PARTS

DESCRIPTION	PART NO.	DESCRIPTION	PART NO.
Collet Body Insulator—Large Size	54N63	Two Piece Power Cable 12 1/2'	46V28-2
Collet Body Insulator	54N01	Two Piece Power Cable 25'	46V30-2
Back Cap Insulator	CNI-18-7	Accessory Kit	AK-3
Cup Gasket	CNI-18CG	Hook Up Kit (for torches using gas solenoid valve on machine)	HK-3
Short Torch Cap	57Y04	Two Piece Connector & Nipple	CNI-26-2
Long Torch Cap	57Y02	Parts Kit	AK-18
Handle	10N15A	Gas Extension Hose (25')	34V38
Power Cable (12 1/2')	46V28	Rubber Power Cable 12 1/2'	46V28R
Power Cable (25')	46V30	Rubber Power Cable 25'	46V30R
Gas Extension Hose (12 1/2')	40V77	Cable Covers 10 Ft. & 20 Ft.	CC-10, CC-20
Power Cable Adaptor	45V62	Handle for 26PH Torch	54N84
2 Piece Argon Hose 12 1/2 Foot	40V75-2		
2 Piece Argon Hose 25 Foot	41V30-2		

## GAS CUPS

Cup No.	4	5	6	7	8	10	12	Short
Ceramic	105Z43	105Z42	105Z44	105Z45	08N78	08N79	08N80	54N36
Ceramic Gas Lens	54N35	54N34	54N33	54N32	54N31	—	—	54N36
Ceramic Long 3 7/32"	12N03	105Z60	12N02	105Z61	10065	—	—	—
Alumina	10N50	10N49	10N48	10N47	10N46	10N45	10N44	—
Alumina Long 3"	—	10N49L	10N48L	10N47L	—	—	—	—
Alumina Gas Lens	54N18	54N17	54N16	54N15	54N14	—	—	54N19
Alumina Gas Lens Long 3"	—	54N17L	54N16L	54N15L	—	—	—	—
Alumina Large Dia.						53N88	53N87	53N89

## COLLET BODIES & COLLETS

Electrode Diam. (in.)	.020	.040	1/16	3/32	1/8	5/32
Collet	10N21	10N22	10N23	10N24	10N25	54N20
Standard Collet Body	10N29	10N30	10N31	10N32	10N28	406488
*Gas Lens Collet Body	45V29	45V24	45V25	45V26	45V27	45V28
Large Dia. Gas Lens Collet Body				45V64	995795	45V63

\*Collet Body Insulator #54N01 Required When Using Gas Lens Collet Bodies

Collet Body Insulator #54N63 Required When Using Large Dia. Gas Lens Collet Bodies

Interchangeable Parts — The CNI-26 uses the same gas cups, collets, collet bodies, and torch caps as the CNI-17,  
CNI-18, and "Linde" HW-17, HW-18, and HW-26 torches.

# CNI-26VH & PH TORCH



## AIR COOLED TIG TORCH

Available With Heavy Duty Rubber Power Cable  
or 2 Piece Power Cable

- Capacity ..... 200 amps  
continuous  
duty
- Weight, less cable and hoses .... 10 oz.
- Electrode capacity ..... 020 - 5/32 in.
  - SILICONE RUBBER INSULATION
  - INTERCHANGEABLE PARTS
  - QUALITY CONSTRUCTION

NOTE: for PHENOLIC Torches  
add "PH" to Part No.



DESCRIPTION	PART NO.	DESCRIPTION	PART NO.
TORCH BODY WITH BUILT IN VALVE Includes: Cup Gaskets	CNI-26VH	**TORCH PACKAGE WITH BUILT IN VALVE Includes: Torch Body With Built in Valve, Long Back Cap, Handle, 25' Power Cable	CNI-26VH-25 CNI-26PH-VH-25
PHENOLIC Torch Body With Built In Valve	CNI-26PH-VH		
**TORCH PACKAGE WITH VALVE Includes: Torch Body With Built In Valve, Long Back Cap, Handle, 12 1/2' Power Cable	CNI-26VH-12 CNI-26PH-VH-12	Same as above but with two piece Power Cable Power cable adaptor not necessary with 2-PC power cable	CNI-26VH-25-2PC CNI-26PH-VH-25-2PC
Same as above but with two piece power cable	CNI-26VH-12-2PC CNI-26PH-VH-12-2PC	**Power cable adaptor - optional	45V62

## ACCESSORIES - REPLACEMENT PARTS

DESCRIPTION	PART NO.	DESCRIPTION	PART NO.
Collet Body Insulator—Large Size	54N63	Handle for PH Torch	54N84
Collet Body Insulator	54N01	Valve Stem Assembly	VS-1
Back Cap Insulator	CNI-18-7	Valve Stem O Ring	26-VSO
Cup Gasket	CNI-18CG	Two Piece Power Cable 12 1/2'	46V28-2
Short Torch Cap	57Y04	Two Piece Power Cable 25'	46V30-2
Long Torch Cap	57Y02	Accessory Kit	AK-3
Handle	10N15A	Hook Up Kit (for torches with built in valve)	HK-2
Power Cable (12 1/2')	46V28	Hook Up Kit (for torches using gas solenoid valve on machine)	HK-3
Power Cable (25')	46V30	Two Piece Connector & Nipple	CNI-26-2
Gas Extension Hose (12 1/2')	40V77	Parts Kit	AK-18
Power Cable Adaptor	45V62	Gas Hose Extension (25')	34V38
2 Piece Argon Hose 12 1/2 Foot	40V75-2		
2 Piece Argon Hose 25 Foot	41V30-2		

## GAS CUPS

Cup No.	4	5	6	7	8	10	12	Short
Ceramic	105Z43	105Z42	105Z44	105Z45	08N78	08N79	08N80	54N36
Ceramic Long 3 7/32"	12N03	105Z60	12N02	105Z61	10065	—	—	—
Alumina	10N50	10N49	10N48	10N47	10N46	10N45	10N44	—
Alumina Long 3"	—	10N49L	10N48L	10N47L	—	—	—	—
Alumina Gas Lens	54N18	54N17	54N16	54N15	54N14	—	—	54N19
Alumina Gas Lens Long 3"	—	54N17L	54N16L	54N15L	—	—	—	—
Alumina Large Dia.	—	—	—	—	—	53N88	53N87	53N89

## COLLET BODIES & COLLETS

Electrode Diam. (in.)	.020	.040	1/16	3/32	1/8	5/32
Collet	10N21	10N22	10N23	10N24	10N25	54N20
Standard Collet Body	10N29	10N30	10N31	10N32	10N28	406488
*Gas Lens Collet Body	45V29	45V24	45V25	45V26	45V27	45V28
Large Dia. Gas Lens Collet Body	—	—	—	45V64	995795	45V63

\*Collet Body Insulator #54N01 Required When Using Gas Lens Collet Bodies

Collet Body Insulator #54N63 Required When Using Large Dia. Gas Lens Collet Bodies

Interchangeable Parts — The CNI-26VH uses the same gas cups, collets, collet bodies, and torch caps as the CNI-17, CNI-18, and "Linde" HW-17, HW-18, and HW-26 torches.

### REPLACEMENT COLLETS For LINDE & CNI TORCHES

COLLETS	PART NO.	SIZE	USED ON
		84Z33S	3/32"
84Z33		1/16"	HW-90PH
84Z34		.020	"
84Z35		.040	"
84Z59		.040	HW-10-HW-12
84Z60		1/16"	"
84Z61		3/32"	"
84Z62		1/8"	"
105Z41		.020	HW-17
105Z46		.040	"
105Z47		1/16"	"
105Z48		3/32"	"
10N21		.020	HW-18-17-26
10N22		.040	"
10N23		1/16"	"
10N24		3/32"	"
10N25		1/8"	"
54N20		5/32"	"
SP-30028		3/16"	CNI-18S
13N20		.020	HW-20-25
13N21	.040	"	
13N22	1/16"	"	
13N23	3/32"	"	
13N24	1/8"	"	
53N15	.020	HW-24	
53N16	.040	"	
53N14	1/16"	"	
53N64	1/16"	HW-24	
53N63	.040	GAS LENS	
53N62	.020	"	
85Z16	1/8"	HW-12	
85Z17	5/32"	HW-12	
85Z18	3/16"	HW-12	
85Z19	1/4"	HW-12	

### REPLACEMENT COLLET BODIES FOR LINDE & CNI TORCHES

COLLET BODIES	PART NO.	SIZE	USED ON
	105Z27		HW 9
	10N29	.020	HW-18-17-26
	10N30	.040	"
	10N31	1/16"	"
	10N32	3/32"	"
	10N28	1/8"	"
	406488	5/32"	HW-17-18-26
	SP-30126	3/16"	CNI-18S
	13N25	.020	HW-20-25
	13N26	.040	"
	13N27	1/16"	"
	13N28	3/32"	"
	13N29	1/8"	"
	53N17	.020	HW-24
	53N18	.040	"
53N19	1/16"	"	

**REPLACEMENT GAS LENS COLLET BODIES For LINDE & CNI TORCHES**

	PART NO.	SIZE	USED ON
COLLET BODIES GAS LENS 	45V29	.020	HW-18-17-26
	45V24	.040	"
	45V25	1/16"	"
	45V26	3/32"	"
	45V27	1/8"	"
	45V28	5/32"	"
	45V41	.020	HW-20-25
	45V42	.040	"
	45V43	1/16"	"
	45V44	3/32"	"
45V45	1/8"	"	

	PART NO.	SIZE	USED ON
LARGE DIA. GAS LENS  Lg. Dia. Stubby Gas Lens available for the CNI-9 & 20	995795	Collet Body 1/8	HW26-27
	45V63	Collet Body 5/32	"
	45V64	Collet Body 3/32	"
	54N70	Outer spacer	"
	54N71	Outer snap ring	"
	54N69	Inner snap ring	"
	54N68	Inner spacer	"
	54N67	Screen 100 mesh	"
	54N66	Screen 250 mesh	"

**REPLACEMENT PARTS For LINDE & CNI TORCHES**

"O" RINGS 	85W49	For Back Cap	HW-9
	84W85	For Torch Body	HW-10 HW-4
	85W50	For Back Cap	HW-18
	85W51	For Torch Body	"
	85W80	For Torch Body	"
	85W07	For Torch Body	FMS-1
	85W55		HW-12
	85W95		HW-17
	98W18	57Y02 Back Cap	HW-18-26
	98W77	Same as 181W53 Cap	HW-20
99W88	Same as 85W49	HW-20	
INSULATORS & GASKETS 	54N63	Insulator	HW-26
	54N01	Insulator	HW-17
	13N07	Teflon Gasket	HW-20
	53N65	Insulator	HW-20
	598882	2 Way Cup Gasket	HW-20
	53N22	Insulating Gasket	HW-24
	53N66	Collet Body Insulator	HW-24
	53N04	Hose Clamp	HW-20
	53N20	Wrench	HW-24
	98W43	Hose Clamp	HW-18
	53N85	Insulator	HW-9
	45V52	Adaptor	HW-9
	59N37	Insulator Bushing	ST-13
	599589	Centering Bushing	ST-13
	598563	Cup Gasket	HW-20
633574	Collet Lock Nut	ST-19	
598648	Ceramic Cup #8	Hot Wire Torch	



## NOVATEX<sup>®</sup> Kevlar Cable Cover







Protective Cable Covering  
(3 inches wide, protection to 900° F.,  
Nylon Zipper)

Now protect your welding power cables  
and hoses with our new covering.

PART NO.	SIZE
CC-8	8 Ft.
CC-10	10 Ft.
CC-20	20 Ft.
CC-24	24 Ft.











### REPLACEMENT LONG LAVA NOZZLES for LINDE & CNI TORCHES

TORCH	SIZE	PART NO.	ORIFICE
 HW-9 1-3/4"	3L	SP-10045	5/32"
	4L	SP-10046	1/4"
	5L	SP-10047	5/16"
	6L	SP-10048	3/8"
 HW-10, 4 2-5/8"	3L	SP-10049	3/16"
	4L	105Z16	1/4"
	5L	105Z59	5/16"
	6L	105Z17	3/8"
	7L	12N01	7/16"
 HW-17, 18, 26 3-7/32"	3L	SP-10076	3/16"
	4L	12N03	1/4"
	5L	105Z60	5/16"
	6L	12N02	3/8"
	7L	105Z61	7/16"
 HW-20, 25 1-7/8"	8L	SP-10065	1/2"
	3L	796F70	3/16"
	4L	796F71	1/4"
	5L	796F72	5/16"
 HW-20, 25 2-1/2"	6L	796F73	3/8"
	3XL	796F74	3/16"
	4XL	796F75	1/4"
	5XL	796F76	5/16"
 HW-20-25 3-1/2"	6XL	796F77	3/8"
	4XXL	796F79	1/4"
	5XXL	796F80	5/16"















**REPLACEMENT LAVA NOZZLES Required for LINDE & CNI TORCHES**

TORCH	SIZE	PART NO.	ORIFICE
HW-4,5 <span style="float: right;">1-15/16"</span> 	4A	SP-10000	1/4"
	5A	SP-10001	5/16"
	6A	81Z51	3/8"
	7A	81Z52	7/16"
	8A	81Z53	1/2"
HW-9 <span style="float: right;">1-5/16"</span> 	3	SP-10005	3/16"
	4	84Z36	1/4"
	5	84Z37	5/16"
	6	84Z86	3/8"
	8	SP-10068	1/2"
HW-10, 12, 13 <span style="float: right;">1-1/4"</span> 	4	85Z07	1/4"
	5	85Z08	5/16"
	6	85Z09	3/8"
	7	85Z10	7/16"
	8	85Z11	1/2"
HW-17, 18, 26 <span style="float: right;">1-27/32"</span> 	3	SP-10019	3/16"
	4	105Z43	1/4"
	5	105Z42	5/16"
	6	105Z44	3/8"
	7	105Z45	7/16"
	8	08N78	1/2"
	10	08N79	5/8"
	12	08N80	3/4"
HW-20, 25 <span style="float: right;">1-5/32"</span> 	4	13N14	1/4"
	5	13N15	5/16"
	6	13N16	3/8"
	7	13N17	7/16"
	8	13N18	1/2"
	10	13N19	5/8"
HW-24 <span style="float: right;">5/8"</span>   <span style="float: right;">1-1/8"</span>	.165	53N23	.165
	4	53N24	1/4"
	5	53N25	5/16"
	6	53N27	3/8"
	4L	53N28	1/4"
	6L	53N26	3/8"
HW-17, 18, 26 <span style="float: right;">1-5/8"</span> 	4	54N35	1/4"
	5	54N34	5/16"
	6	54N33	3/8"
	7	54N32	7/16"
	8	54N31	1/2"
GAS LENS <span style="float: right;">1-1/8"</span>	Short	54N36	11/16"















Packed 10 to a box.

**REPLACEMENT LONG ALUMINA NOZZLES for LINDE & CNI TORCHES**

TORCH	SIZE	PART NO.	ORIFICE
HW-17, 18, 26 3" 	5L	10N49L	5/16"
	6L	10N48L	3/8"
	7L	10N47L	7/16"
HW-17-18-26 3"  Gas Lens	5L	54N17L	5/16"
	6L	54N16L	3/8"
	7L	54N15L	7/16"
	8L	54N14L	1/2"
HW-17-18-26 3-1/2"  Bulbous	7L	SP-20072	7/16"
	8L	SP-20073	1/2"
HW-9 1-7/8" 	4L	14N73	1/4"
	5L	14N74	5/16"
	6L	14N75	3/8"
HW-20, 25 2-1/2" 	4XL	SP-20076	1/4"
HW-10, 4 2-5/8" 	4L	14N68	1/4"
	5L	14N69	5/16"
	6L	14N70	3/8"
	7L	14N71	7/16"
	8L	14N72	1/2"
HW-17, 18, 26 2-3/4" *  Lg. Dia. Gas Lens	6L	57N75L	3/8"
	8L	57N74L	1/2"
	10L	53N88L	5/8"
	12L	53N87L	3/4"
HW-17, 18, 26 3-1/4" *  Lg. Dia. Gas Lens -	6XL	57N75XL	3/8"
	8XL	57N74XL	1/2"
	10XL	53N88XL	5/8"
	12XL	53N87XL	3/4"
HW-17, 18, 26 3-1/2" *  Lg. Dia. Gas Lens Trailer Shield	taper length 1-7/8" O.D. 9/16" x 1-5/16"	SP-20082	1" x 5/16"
HW-17, 18, 26 3-5/8" *  Lg. Dia. Gas Lens Trailer Shield	taper 7/8" length O.D. 5/16" x 3/4"	SP-20083	5/8" x 3/16"
HW-20 2-1/2"  53N60 Modified	taper 1-1/2" length O.D. 5/16" x 3/4"	SP-20085	5/8" x 3/16"
TRAILER SHIELD * 	<b>SP-20086</b> For HW-20.9		
	O.D. 3/4" X 2-1/2"	Height 1-7/8"	I.D. 2-1/4" x 1/2" 1/4" depth
			<b>SP-20086L</b> For HW-17, 18, 26, 27
O.D. 1-1/4" X 3-1/4"	Height 2-7/8"	I.D. 3-1/2" X 1" 1/2" depth	

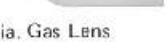
\* Note: These Gas Lens Nozzles must use the large diameter gas lens collet body and 54N63 insulator.





**REPLACEMENT ALUMINA NOZZLES for LINDE & CNI Torches**

TORCH	SIZE	PART NO.	ORIFICE	
HW-4, 5 	1-15/16"	5A	Special	5/16"
		6A	14N62	3/8"
		7A	14N63	7/16"
		8A	14N64	1/2"
HW-9 	1-5/16"	4	14N65	1/4"
		5	14N66	5/16"
		6	14N67	3/8"
		8	Special	1/2"
HW-10, 12, 13 	1-1/4"	4	14N57	1/4"
		5	14N58	5/16"
		6	14N59	3/8"
		7	14N60	7/16"
		8	14N61	1/2"
HW-17, 18, 26 	1-27/32"	4	10N50	1/4"
		5	10N49	5/16"
		6	10N48	3/8"
		7	10N47	7/16"
		8	10N46	1/2"
		10	10N45	5/8"
		12	10N44	3/4"
Metal Shield Cups HW-17, 18, 26 	1-27/32"	10	10N51	5/8"
		8	10N52	1/2"
		7	10N53	7/16"
		6	10N54	3/8"
		5	10N55	5/16"
		4	10N56	1/4"
HW-20, 25 	1-5/32"	4	13N08	1/4"
		5	13N09	5/16"
		6	13N10	3/8"
		7	13N11	7/16"
		8	13N12	1/2"
		10	13N13	5/8"
ST-2 (Short Arc) HW-35 	1-11/16"	6	12N48	3/8"
HW-17, 18, 26 	1 5/8"	4	54N18	1/4"
		5	54N17	5/16"
		6	54N16	3/8"
		7	54N15	7/16"
		8	54N14	1/2"
Gas Lens 	1-1/8"	Short	54N19	11/16"
HW-17-18-26-27 	1-15/16"	12	53N87	3/4"
	1-7/8"	10	53N88	5/8"
	1-7/8"	8	57N74	1/2"
		6	57N75	3/8"
	Lg. Dia. Gas Lens 	15/16"	Short	53N89
HW-20, 24, 25 	1"	4	53N58	1/4"
		5	53N59	5/16"
		6	53N60	3/8"
		7	53N61	7/16"
	Gas Lens Available in Long 	2 5/16"	8	53N61-S
HW-20 	1"	10	SP-20069	5/8"
		12	SP-20070	3/4"
Gas Lens 				

Note: Packed 10 to a box.

\*Note: These Gas Lens Nozzles must use the large diameter gas lens collet body and 54N63 insulator.

Required for LINDE & CNI TORCHES

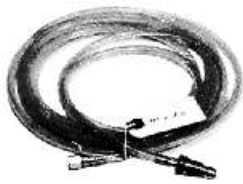
	PART NO.	CODE-ITEM	SIZE	USED ON	
	46V28	2982-50001	12-1/2 Ft. Power Cable	HW-26 - CNI-26	
	46V28-2	2982-50038	12 1/2 Ft. 2 Pc. Power Cable	" "	
	46V30	2982-50000	25 Ft. Power Cable	" "	
	46V30-2	2982-50039	25 Ft. 2Pc. Power Cable	" "	
	46V30-2-50	2982-50053	50 Ft. Power Cable 2 Pc.	" "	
	40V75-2	2982-50049	12-1/2 Ft. Argon Hose 2 Pc.	" "	
	41V30-2	2982-50050	25 Ft. Argon Hose 2 Pc.	" "	
	41V30-2-50	2982-50055	50 Ft. Argon Hose 2 Pc.	" "	
		40V82	2982-50009	12-1/2 Ft. Argon Hose	HW-12, 13, 27
		40V83	2982-50008	12-1/2 Ft. Water Hose	" " " "
40V84		2982-50010	12-1/2 Ft. Power Cable	" " " "	
40V82-L		2982-50032	25 Ft. Argon Hose	" " " "	
40V83-L		2982-50033	25 Ft. Water Hose	" " " "	
40V84-L		2982-50034	25 Ft. Power Cable	" " " "	
40V78		2982-50037	12-1/2 Ft. Power Cable Ext.	HW-18	
40V78-L		2982-50056	25 Ft. Power Cable Ext.	" "	
56Y38		2982-50022	12-1/2 Ft. Power Cable	HW-9 & HW-24 CNI-9-24	
56Y97		2982-50023	25 FT. Power Cable	" "	
34V38	2982-50046	25 FT. Argon Hose Ext.	ST-14, HW-24, CNI-24-26		
	40V76	2982-50011	12-1/2 Ft. Water Hose Ext.	HW-12, 13, 18, 20	
	40V77	2982-50012	12-1/2 Ft. Argon Hose Ext.	HW-13, 17, 18, 20, 26	
	40V76-L	2982-50035	25 Ft. Water Hose Ext.	HW-12, 13, 18, 20	
	40V77-L	2982-50036	25 Ft. Argon Hose Ext.	HW-12, 13, 17, 18, 20, 26	
		40V75	2982-50014	12-1/2 Ft. Argon Hose	HW-18 Torch CNI-18
40V74		2982-50013	12-1/2 Ft. Water Hose	" "	
40V64		2982-50015	12-1/2 Ft. power Cable	" "	
41V30		2982-50017	25 Ft. Argon Hose	" "	
41V32		2982-50016	25 Ft. Water Hose	" "	
41V29		2982-50018	25 Ft. Power Cable	HW-18 Torch	
41V30-50		2982-50058	50 Ft. Argon Hose	HW-18 Torch	
41V32-50		2982-50059	50 Ft. Water Hose	HW-18 Torch	
41V29-50		2982-50065	50 Ft. Power Cable	HW-18 Torch	
41V29-M		2982-50047	25 Ft. Power Cable, Machine Fitting Both Ends		
	45V09	2982-50030	12-1/2 Ft. Argon Hose	HW-20 & HW-25 CNI-20	
	45V07	2982-50028	12-1/2 Ft. Water Hose	" "	
	45V03	2982-50024	12-1/2 Ft. Power Cable	" "	
	45V10	2982-50031	25 Ft. Argon Hose	" "	
	45V08	2982-50029	25 Ft. Water Hose	" "	
	45V04	2982-50025	25 Ft. Power Cable	" "	
	45V10L	2982-50045	50 Ft. Argon Hose	" "	
	45V08L	2982-50044	50 Ft. Water Hose	" "	
	45V04L	2982-50043	50 Ft. Power Cable	" "	
		57Y01	2982-50019	12-1/2 Ft. Power Cable	HW-17 Torch CNI-17
57Y03		2982-50020	25 Ft. Power Cable	" "	
57Y03-50		2982-50066	50 Ft. Power Cable	" "	
57Y01-2		2982-50040	12-1/2 Ft. 2 Pc. Power Cable	" "	
57Y03-2		2982-50041	25 Ft. 2 Pc. Power Cable	" "	
57Y03-2-50		2982-50054	50 Ft. Power Cable 2 Pc.	" "	
45V09-2		2982-50051	12-1/2 Ft. Argon Hose 2 Pc.	" "	
45V10-2		2982-50052	25 Ft. Argon Hose 2 Pc.	" "	
45V10-2-50		2982-50057	50 Ft. Argon Hose 2 Pc.	" "	

SPECIAL HEAVY DUTY RUBBER POWER CABLES

46V28-R	2982-50060	12-1/2 Ft. Power Cable	HW-26 CNI-26
46V30-R	2982-50061	25 Ft. Power Cable	HW-26 CNI-26
57Y01-R	2982-50062	12-1/2 Ft. Power Cable	HW-17, CNI-9,17
57Y03-R	2982-50063	25 Ft. Power Cable	HW-17, CNI-9,17
56Y38-R	2982-50068	12-1/2 Ft. Power Cable	HW-9,24,CNI-9PH,24
56Y97-R	2982-50069	25 Ft. Power Cable	HW-9,24,CNI-9PH,24
40V64-R	2982-50067	12-1/2 Ft. Power Cable	HW-18, CNI-18
41V29-R	2982-50064	25 Ft. Power Cable	HW-18, CNI-18
*45V03-R	2982-50070	12-1/2 Ft. Power Cable	HW-20, CNI-20
*45V04-R	2982-50071	25 Ft. Power Cable	HW-20, CNI-20

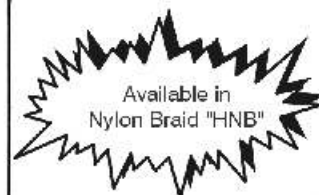

\*53N06HD Handle and HA-20 Adaptor required when using Rubber Cable

### REPLACEMENT PARTS FOR TORCHES

	PART NO.	DESCRIPTION	USED ON	
<b>Fittings</b>   45V05   45V06   57Y10	10N15	Handle	HW-18	
	10N15-A	Handle	CNI-26, 26VH	
	10N18	Nut, adaptor end	HW-18,20	
	10N27	Insulating sleeve	HW-18	
	11N16	Water hose adaptor		
	11N17	Adaptor RH coupler		
	11N18	Adaptor LH coupler		
	11N19	Coupling	HW-18	
	11N19-IS	Insulating sleeve		
	11N22	Nipple Hose, water adaptor end	HW-18	
	11N37	Current nipple, torch end	HW-18	
	11N38	Current nipple, adaptor end	HW-18	
	11N83	Nut, adaptor end	HW-18,20	
	13N07	Teflon gasket	HW-20	
	35N22	Hose nipple "B"-1/4"		
	38Z87	Ferrule, adaptor end	HW-18	
	39Z88	Ferrule, adaptor end	HW-24	
	39Z89	Ferrule, adaptor end	CNI-9, 17, 18	
	41V24	Long cap	HW-20	
	41V33	Short cap	HW-20	
	41V35	Medium cap	HW-20	
	45V05	Current nipple, torch and	HW-20	
	45V06	Current nipple, adaptor end	HW-20	
	45V52	Adaptor	HW-9	
	45V67	Current nipple, torch and	HW-26	
45V68	Current nipple, adaptor end	HW-26		
48N22	Nut, adaptor end	HW-26		
53N04	Wire clamp	HW-20		
53N06	Handle	HW-20		
53N06-R	Ribbed handle	HW-9, 20		
53N06-HD	Handle for Heavy Duty Rubber Cables	CNI-20, 20PH		
HA-20	Handle adaptor	53N06HD		
53N10	Hose nipple adaptor end	HW-20		
53N10-A	Nipple, gas hose	HW-20		
53N20	Wrench	HW-24		
53N21	Handle	HW-24		
53N22	Insulating gasket	HW-24		
53N65	Insulator	HW-20		
53N66	Collet body insulator	HW-24		
53N67	Insulator	HW-25		
53N85	Insulator	HW-9		
54N01	Insulator	HW-17		
54N63	Insulator	HW-26		
54N84	Handle	HW-26		
54N98	Ferrule, adaptor end	HW-26		
56Y39	Current nipple, adaptor end	HW-24		
56Y40	Long cap	HW-9		
57Y02	Long cap	HW-18		
57Y04	Short cap	HW-18		
57Y10	Current nipple, adaptor end	CNI-9, 17		
59N37	Insulator bushing	ST-13		
84Z28	Handle	HW-9		
84Z31	Short cap	HW-9		
85Z99	Cup gasket	HW-20		
105Z26	Sleeve	HW-9		
105Z55	Handle	HW-17		
105Z55RD	Ribbed Handle	HW-105		
136Z08	Gas nut, adaptor end	HW-20		
598563	Cup gasket	HW-20		
598648	Ceramic cup #8	Hot Wire Torch		
599589	Centering bushing	ST-13		
633574	Collet lock nut	ST-13		
<b>Back Caps</b>   41V33  41V35  57Y04   57Y02   41V24				
	<b>Handles</b>   57Y02   41V24   84Z28			

## Hook-Up Kits

### WATER COOLED TORCHES

#### KIT #HK-1

- Includes: 1 - Power Cable adaptor  
 2 - Water hoses, 12-1/2' with IAA fittings.  
 2 - Water adaptor fittings, 1/4" NPT male to IAA fittings.  
 1 - Gas hose, 12-1/2' with IAA fittings.

### AIR COOLED TORCHES

#### KIT #HK-2

- (for torches with built-in gas valve)  
 Includes: 1 - Gas hose, 12-1/2' with IAA fittings.

#### KIT #HK-3

- (for torches using gas solenoid valve on machine)  
 Includes: 1 - Gas hose, 12-1/2' with IAA fittings.  
 1 - Gas hose, 18" with IAA fittings.

### ACCESSORY KITS

### USED ON

AK-1	CNI-9
AK-2	CNI-17
AK-3	CNI-18,26
AK-4	CNI-20
AK-20	CNI-20
AK-18	CNI-17, 18,26
AK-20-B	Box Only
AK-18-B	Box Only

### HOOK UP KITS

### USED ON

HK-1	ALL
HK-2	Torches w/valve
HK-3	Torches w/solenoid

## GAS CONTROL VALVES

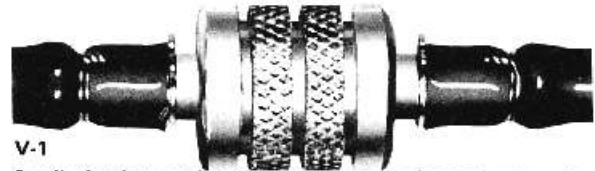

V-1

Small aluminum valve that mounts in gas hose of any water cooled torch. Also makes excellent general purpose valve for purge hoses, etc. Can be used in gas hose of air cooled torches using 2 piece power cable assembly.

## POWER CABLE ADAPTORS (ONE PIECE)

POWER CABLE ADAPTORS	PART NO.	DESCRIPTION	USED ON
	105Z57	Adaptor	HW-9
	45V11	Adaptor	HW-17
	45V11	Adaptor	HW-18,20,25, 12,13,27
	45V62	Adaptor	HW-26



DINSE CONNECTOR	USED ON	MALE END DIA.	POWER CABLE CONN.
LDT-917-F	9,17	.508 (12.9mm)	3/8-24 (M) Air Cooled
LDTI-917-F	9,17	.508 (12.9mm)	3/8-24 (M) Air Cooled (in line)
LDT-24-M	24	.508 (12.9mm)	3/8-24 (F) Air Cooled
LDT-26-R	26	.508 (12.9mm)	7/8-18 (R.H.) Air Cooled
LDTI-26-R	26	.508 (12.9mm)	7/8-14 (R.H.) Air Cooled (in line)
LDT-1820-L	18,20	.508 (12.9mm)	7/8-18 (L.H.) Water Cooled
LDTS-917-F	9,17	.355 (9.0 mm)	3/8-24 (M) Air Cooled

# CNI-10PH TORCH



## Water Cooled 350 amp TIG Torch

350 Amp. continuous duty.  
350 to 500 amps. at reduced duty cycles.  
Water flo- 18-1/2 gallons per hour.  
Water pressure - 30 to 75 psi.  
Do not operate at lower than 30 psi.  
Over 75 psi. use water regulator.  
Electrodes .020" to 3/16".

### CNI-10PH-12 Outfit includes

- #10 Torch Body
- Long Back Cap
- Handle
- 12½ ft. Power Cable & Hoses

### CNI-10PH-25 Outfit includes

- #10 Torch Body
- Long Back Cap
- Handle
- 25' Power Cable & Hoses

### ACCESSORIES - REPLACEMENT PARTS

DESCRIPTION	PART NO.	DESCRIPTION	PART NO.
Torch Body	10PH	Power Cable Nipple-torch end	10PH-27
Short Cap	10PH-01	Power Cable Nipple-adaptor end	10PH-28
Long Cap	10PH-02	Power Cable Ferrule	10PH-32
Handle	10PH-03	Water Hose Nipple - adaptor end	10PH-30
Power Cable 12½'	10PH-04	Water Hose Ferrule	10PH-31
Water Hose 12½'	10-PH-05	Argon Hose Nipple-adaptor end	10PH-29
Argon Hose 12½'	10PH-06	Argon Hose Ferrule	10PH-31
Power Cable 25'	10PH-07		
Water Hose 25'	10PH-08		
Argon Hose 25'	10PH-09		
O Ring	10PH-10		

### COLLETS #10

Electrode Diam. (in.)	.020	.040	1/16	3/32	1/8	5/32	3/16
	10PH-11	10PH-12	10PH-13	10PH-14	10PH-15	10PH-16	10PH-17

### GAS CUPS #10

Cup No.	3	4	5	6	7	8	10
Ceramic		85Z07	85Z08	85Z09	85Z10	85Z11	10018
Long Ceramic 2-5/8	10049	105Z16	105Z59	105Z17	12N01	105Z18	
Alumina		14N57	14N58	14N59	14N60	14N61	
Long Alumina 2-5/8		14N68	14N69	14N70	14N71	14N72	

SPECIAL - LONG CUPS AVAILABLE





# CNI-H16 AND VH TORCH



## AIR COOLED TIG TORCH

Two Piece Power Cable  
Available at no Extra Charge

- Capacity . . . . . 200 amps continuous duty
- Weight, less cable and hoses . . . . 6 oz.
- Electrode capacity . . . . . 020 - 3/16"
- MOLDED TORCH BODY AND HANDLE
- INTERCHANGEABLE PARTS WITH AIRCO
- QUALITY CONSTRUCTION
- BRAIDED RUBBER CABLES



### REPLACEMENT FOR AIRCO

DESCRIPTION	PART NO.	DESCRIPTION	PART NO.
TORCH BODY	CNI-16PH	**TORCH PACKAGE	CNI-16PH-25
TORCH BODY WITH VALVE	CNI-16PH-VH	Includes: Torch Body	
**TORCH PACKAGE	CNI-16PH-12	Long Back Cap, Handle	CNI-16PH-VH-25
Includes: Torch Body		25' Power Cable	
Long Back Cap, Handle	CNI-16PH-VH-12	TORCH PACKAGE	CNI-16PH-25-2PC
1 1/2 Power Cable		Same as above but with two	CNI-16PH-VH-25-2PC
TORCH PACKAGE	CNI-16PH-12-2PC	piece power cable	
Same as above but with two		Power cable adaptor not necessary	
piece power cable	CNI-16PH-VH-12-2PC	with 2-PC power cable	
		**Power Cable Adaptor — Optional	2310-1879

### ACCESSORIES - REPLACEMENT PARTS

DESCRIPTION	PART NO.	DESCRIPTION	PART NO.
Torch Body	CNI-16PH	Two Piece Power Cable 12 1/2'	46V28-2
Torch Body with valve	CNI-16PH-VH	Two Piece Power Cable 25'	46V30-2
Handle	CNI-16H	Accessory Kit AK-16	2310-1958
Long Back Cap	2304-0145	Hook Up Kit (for torches using gas solenoid valve on machine)	HK-3
Medium Back Cap	2304-0144	Hook Up Kit (for torches with built-in gas valve)	HK-2
Short Back Cap	2304-0143	Two Piece Connector & Nipple	CNI-26-2
Torch Body "O" Ring	2310-0733	12 1/2 Ft. Power Cable	2310-1206
Nose Block	2310-1938	25 Ft. Power Cable	2310-1213
Valve Stem	VS-16	10 Ft. Cable Cover	CC-10
Back Cap "O" Ring	2310-0040	20 Ft. Cable Cover	CC-20

### COLLETS

Electrode Diam. (in.)	.020	.040	1/16	3/32	1/8	5/32	3/16
Collet (Steel)	0086	0087	0088	0089	0090	0091	0146
Collet (Copper)	0086-C	0087-C	0088-C	0089-C	0090-C	0091-C	—

### GAS CUPS

Cup No.	3	4	5	6	7	8	10
Ceramic 1-5/8"	—	0079C	0080C	0081C	11019	0082C	0083C
Ceramic Short 1-1/4"	—	0084C	—	—	—	0085C	—
Ceramic Long 3"	3L	4L-79	5L-80	6L-81	—	8L-82	—
Alumina 1-5/8"	—	0079	0080	0081	—	0082	0083
Alumina Short 1-1/4"	—	0084	—	—	—	0085	—

Interchangeable Parts — All parts interchangeable with AIRCO.

### WATER COOLED TIG TORCH

- Capacity . . . . . 200 amps continuous duty
- Weight, less cable & hose . . . . . 3 oz.
- Cooling Requirements . . . . . 1 qt./min.
- Electrode capacity . . . . . .020 - 1/8"

- INTERCHANGEABLE PARTS WITH AIRCO
- QUALITY CONSTRUCTION
- MOLDED TORCH BODY AND HANDLE
- FLEXIBLE BRAIDED RUBBER POWER CABLE WITH HOSES IN PROTECTIVE SHEATH



### REPLACEMENT FOR AIRCO

DESCRIPTION	PART NO.	DESCRIPTION	PART NO.
TORCH BODY	CNI-H-20	*TORCH PACKAGE Includes: CNI-H-20 Torch Body, Long Back Cap, Handle, "O" Ring, Nose Transfer Block, 25' Power Cable & Hoses	CNI-H-20-25
*TORCH PACKAGE Includes: CNI-H-20 Torch Body, Long Back Cap, Handle, "O" Ring, Nose Transfer Block, 12½' Power Cable & Hoses	CNI-H-20-12		
		*Power Cable Adaptor – Optional	2310-1824

### ACCESSORIES & REPLACEMENT PARTS

DESCRIPTION	PART NO.	DESCRIPTION	PART NO.
Torch Body	CNI-H-20	Power Cable 12 1/2'	2310-1817
Handle	2310-1815	Water Hose 12 1/2'	2310-1808
Long Back Cap	2304-0010	Argon Hose 12 1/2'	2310-1806
Medium Back Cap	2304-0009	Power Cable 25'	2310-1818
Short Back Cap	2304-0008	Water Hose 25'	2310-1807
Nose Transfer Block	2310-1810	Argon Hose 25'	2310-1805
Back Cap "O" Ring	2310-0040	3-Hose & Cable Assembly 12 1/2'	2310-1935
Accessory Kit	2310-1957	3-Hose & Cable Assembly 25'	2310-1936
Hook-up Kit	HK-1	Power Cable Adaptor	2310-1824
Torch Body "O" Ring	2310-0019	Cable Covers – 10 ft and 20 ft.	CC-10, CC-20

### COLLETS

Electrode Diam. (in.)	.020	.040	1/16	3/32	1/8
Collet (Steel)	2304-0138	2304-0137	2304-0136	2304-0135	—
Collet (Copper)	2304-0138C	2304-0137C	2304-0136C	2304-0135C	2304-0068

### GAS CUPS

Cup Number	3	4	5	6	7
Ceramic 1-9/16"	11001	2304-0002	2304-0004	2304-0049	2304-0050
Ceramic Short 1-1/8"	—	2304-0005	2304-0023	—	—
Ceramic Long 2-1/16"	3L-A	4L-A	5L-A	6L-A	—
Ceramic Extra Long 3-5/8"	3L-A-XL	4L-A-XL	5L-A-XL	6L-A-XL	—
Alumina 1-9/16"	—	2304-0069	2304-0070	2304-0073	2304-0074
Alumina Short 1-1/8"	—	2304-0071	2304-0072	—	—

**Interchangeable Parts** – All parts interchangeable with AIRCO.

# CNI- H35 TORCH

## WATER COOLED TIG TORCH

- Capacity . . . . . 350 amps continuous duty.
- Weight, less cable and hose . . . . . 5 oz.
- Cooling requirements . . . . . 1 qt./min.
- Electrode capacity . . . . . .020 - 3/16"



- INTERCHANGEABLE PARTS WITH AIRCO
- QUALITY CONSTRUCTION
- MOLDED TORCH BODY AND HANDLE
- FLEXIBLE BRAIDED RUBBER POWER CABLE

## REPLACEMENT FOR AIRCO

DESCRIPTION	PART NO.	DESCRIPTION	PART NO.
TORCH BODY	CNI-35PH	*TORCH PACKAGE	CNI-35PH-25
*TORCH PACKAGE Includes: CNI-35PH Torch Body Long Back Cap Handle 12½' Power Cable & Hoses	CNI-35PH-12	Includes: CNI-35PH Torch Body Long Back Cap Handle 25' Power Cable & Hoses	
		*Power Cable Adaptor – Optional	2310-0735

## ACCESSORIES & REPLACEMENT PARTS

DESCRIPTION	PART NO.	DESCRIPTION	PART NO.
Torch Body	CNI-35PH	Power Cable 12½'	2310-1856
Handle	CNI-35H	Water Hose 12½'	2310-1871
Long Back Cap	2304-0145	Argon Hose 12½'	2310-1873
Medium Back Cap	2304-0144	Power Cable 25'	2310-1857
Short Back Cap	2304-0143	Water Hose 25'	2310-1870
Nose Block	2310-1938	Argon Hose 25'	2310-1869
Back Cap "O" Ring	2310-0040	3-Hose & Cable Assembly 12½'	2310-1953
Accessory Kit AK-35	2310-1958	3-Hose & Cable Assembly 25'	2310-1954
Hook-up Kit	HK-1	Power Cable Adaptor	2310-0735
Torch Body "O" Ring	2310-0733	Cable Covers – 10 ft. and 20 ft.	CC-10, CC-20

## COLLETS







Electrode Diam. (in.)	.020	.040	1/16	3/32	1/8	5/32	3/16
Collet (Steel)	2304-0086	2304-0087	2304-0088	2304-0089	2304-0090	2304-0091	2304-0146
Collet (Copper)	2304-0086C	2304-0087C	2304-0088C	2304-0089C	2304-0090C	2304-0091C	—

## GAS CUPS





Cup Number	3	4	5	6	7	8	10
Ceramic 1-5/8"	—	2304-0079C	2304-0080C	2304-0081C	11019	2304-0082C	2304-0083C
Ceramic Short 1-1/4"	—	2304-0084C	—	—	—	2304-0085C	—
Ceramic Long 3"	3L	4L-79	5L-80	6L-81	—	8L-82	—
Alumina 1-5/8"	—	2304-0079	2304-0080	2304-0081	—	2304-0082	2304-0083
Alumina Short 1-1/4"	—	2304-0084	—	—	—	2304-0085	—

Interchangeable Parts – All parts interchangeable with AIRCO.

**REPLACEMENT LAVA NOZZLES Required for AIRCO Torches**







TORCH TYPE	PART NO.	ORIFICE
H8, H10 H12, H20 	Special	3/16"
	2304-0002	1/4"
	2304-0004	5/16"
	2304-0049 2304-0050	3/8" 7/16" (Std. Lgth.)
H8, H10 H12, H20 	2304-0005 2304-0023	1/4" 5/16" (Short Lgth.)
M50, H50 	2304-0042 2304-0043 2304-0044 2304-0045	1/4" 3/8" 1/2" 5/8"
H35A, M40A, B 	2304-0012 2304-0013	1/4" 5/16"
H16A, B H35B 	2304-0079C 2304-0080C 2304-0081C 2304-0082C 2304-0083C Special	1/4" 5/16" 3/8" 1/2" 5/8" 7/16"
1-1/4" Short 	2304-0084C 2304-0085C	1/4" 1/2"

**REPLACEMENT LONG – Straight Shank – LAVA NOZZLES for AIRCO TORCHES**

TORCH TYPE	PART NO.	ORIFICE
H8, H10 H12, H20 	3L-A	5/32"
	4L-A	1/4"
	5L-A	5/16"
	6L-A	3/8"
H8, H10 H12, H20 	3L-A-X-Long 4L-A-X-Long 5L-A-X-Long 6L-A-X-Long	3/16" 1/4" 5/16" 3/8"
H16A, B H35B 	3L 4L-79 5L-80 6L-81 8L-82	3/16" 1/4" 5/16" 3/8" 1/2"
	5L-80-4 6L-81-4	5/16" 3/8"
  0190	2320-0190 2320-0191	Insulator Cap Spacer



Note: Packed 10 to a box.

**REPLACEMENT ALUMINA NOZZLES Required for AIRCO Torches**





TORCH TYPE	PART NO.	ORIFICE
HB, H10 1-9/16" H12, H20 	2304-0069 2304-0070 2304-0073 2304-0074	1/4" 5/16" 3/8" 7/16"
1-1/8"  Short	2304-0071 2304-0072	1/4" 5/16"
M50, H50 2-1/16" 	2304-0075 2304-0076 2304-0077 2304-0078	1/4" 3/8" 1/2" 5/8"
H16A, B 1-5/8" H35B 	2304-0079 2304-0080 2304-0081 2304-0082 2304-0083	1/4" 5/16" 3/8" 1/2" 5/8"
1-1/4"  Short	2304-0084 2304-0085	1/4" 1/2"
	2304-0047	NOZZLE SPACER H50A-M50A, B, C, D, E

Note: Packed 10 to a box.

**REPLACEMENT BACK CAPS FOR AIRCO TORCHES**

<b>"O" RINGS</b> 	2310-0019 2310-0733 2310-0040 2389-3686	For Holder For Holder For Cap For Holder	H8, H10, H12, H20 H16, A, B-H35B H8, H10, H12, H20 H35A, H50A, M40A, B
	2310-1810 2310-1938	Nose Transfer Block Nose Transfer Block	H-20C H16, H35

**REPLACEMENT BACK CAPS FOR AIRCO TORCHES**

2304-0009 	<b>AIRCO NO.</b>	<b>SIZE</b>
2304-0010 	2304-0008	2" Back cap H-10, H-20
2304-0145 	2304-0009	3" Back cap H-10, H-20
2304-0144 	2304-0010	7" Back cap H-10, H-20
	2304-0143	2" Back cap H-16, H-35
	2304-0144	3" Back cap H-16, H-35
	2304-0145	7" Back cap H-16, H-35

### REPLACEMENT COLLETS FOR AIRCO TORCHES

COLLETS	PART NO.	SIZE	USED ON
	2304-0026	.020	H8, H10, H12, H20
	2304-0006	.040	H8, H10, H12, H20
	2304-0007	1/16"	H8, H10, H12, H20
	2304-0027	3/32"	H8, H10, H12, H20
	2304-0086	.020	H35B, H16A, B
	2304-0087	.040	H35B, H16A, B
	2304-0088	1/16"	H35B, H16A, B
	2304-0089	3/32"	H35B, H16A, B
	2304-0090	1/8"	H35B, H16A, B
	2304-0091	5/32"	H35B, H16A, B
	2304-0146	3/16"	H35B
TELLURIUM COPPER 	2304-0086C	.020	H35B, H16A, B
	2304-0087C	.040	H35B, H16A, B
	2304-0088C	1/16"	H35B, H16A, B
	2304-0089C	3/32"	H35B, H16A, B
	2304-0090C	1/8"	H35B, H16A, B
	2304-0091C	5/32"	H35B, H16A, B
	PLATED STEEL 	2304-0135	3/32"
2304-0136		1/16"	H10, 10B, 20A, 8, 8A
2304-0137		.040	H10, 10B, 20A, 8, 8A
2304-0138		.020	H10, 10B, 20A, 8, 8A
TELLURIUM COPPER 		2304-0068	1/8"
	2304-0135C	3/32"	H10, 10B, 20A, 8, 8A
	2304-0136C	1/16"	H10, 10B, 20A, 8, 8A
	2304-0137C	.040	H10, 10B, 20A, 8, 8A
	2304-0138C	.020	H10, 10B, 20A, 8, 8A

	AIRCO NO.	SIZE	USED ON
	2304-0032	.040	H 50A
	2304-0033	1/16"	M-50A, M-50B, M-50E
	2304-0034	3/32"	M-35A
	2304-0035	1/8"	
	2304-0036	3/16"	
	2304-0037	5/32"	

### POWER CABLE ADAPTORS FOR AIRCO TORCHES

2310-1645	CNI-H-10, H-10VH
2310-1879	CNI-16PH, 16PH-VH
2310-1824	CNI-H-20
2310-0735	CNI-35PH

### ACCESSORY KITS FOR AIRCO TORCHES

2310-1957	H-10, H-20
2310-1958	H-16, H-35

### HANDLES FOR AIRCO TORCHES

2310-1852	CNI-H-10, 10VH
CNI-16H	CNI-16PH, 16PH-VH
2310-1815	CNI-H-20
CNI-35H	CNI-35PH